

# Caston II

## Crane Scale

- Available in 500 × 0.2 kg, 1000 × 0.5 kg, 2000 × 1 kg, 3000 × 2 kg or 5000 × 2 kg Capacities
- Easy-to-Read 1.2" LED Display
- Wireless Remote Control Standard
- Battery Operated

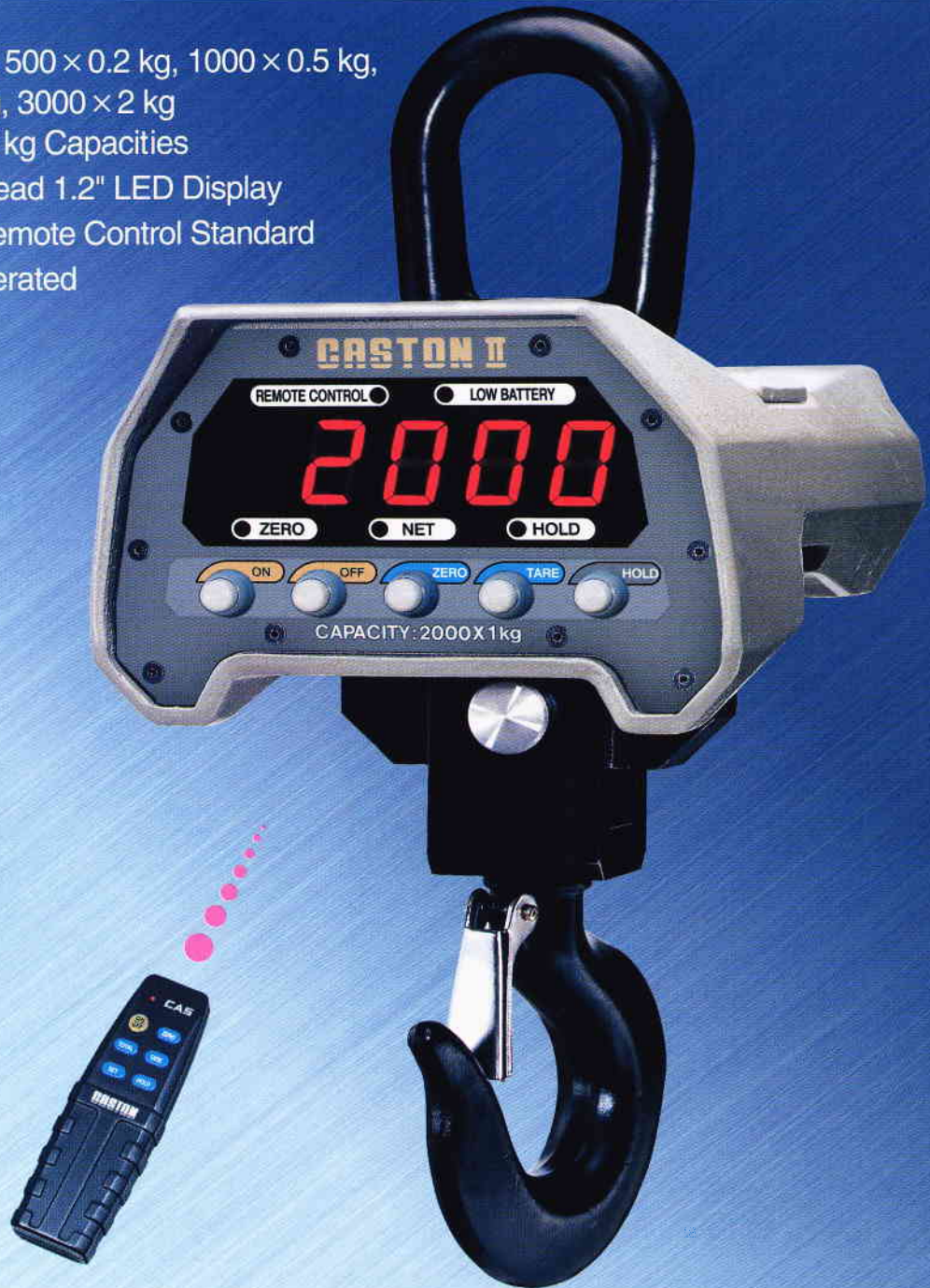

**CAS**



# CASTON II Crane Scale

## FEATURES

- Battery Operated with Low Battery Indication
- Rechargeable Battery Pack
- Spare Battery Pack and Charger Included as Standard
- Remote Control Included as Standard
- On, Off, Zero, Tare, and Hold (Manual or Automatic) Functions
- Easy-to-Read 1.2" LED Display
- Auto Span Adjustment
- Auto Zero Tracking

## SPECIFICATIONS

Model	0.5 THB	1 THB	2 THB	3 THB	5 THB
Weighing Capacity	500×0.2kg	1000×0.5kg	2000×1kg	3000×2kg	5000×2kg
Maximum Tare	Full Tare				
Display Type	LED(1.2 inch)				
Operating Power	DC 6V				
Power Source	AC 110/120/220/24V, 50 / 60Hz				
Display Designators	Zero, Tare, Hold, Batt.				
Power Consumption	1W				
Operating Temperature	-10°C ~ +40°C				
Product Weight	17kg				

## DIMENSIONS

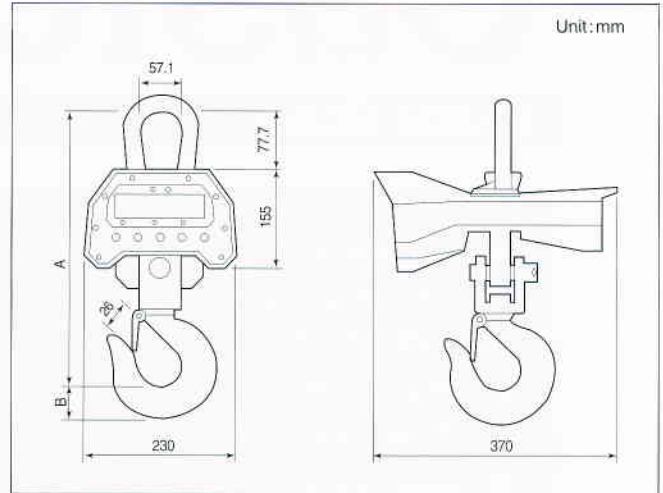

Model	A	B
0.5 THB	350	30
1 THB	350	30
2 THB	430	44.5
3 THB	430	44.5
5 THB	474	44.5



▲ Display & Key board



▶ Battery Pack Installation

# CAS

CAS BLDG., # 440-1, SUNGNAE-DONG,  
GANGDONG-GU, SEOUL, KOREA  
TEL : 82 - 2 - 2225 - 3500  
FAX : 82 - 2 - 475 - 4668  
<http://www.cas.co.kr>

Specifications are subject to change for improvement without prior notice.